

THE INFORMATION CONTAINED IN THIS DRAWING IS THE SOLE PROPERTY OF MASTERPIECE ARMS INC.. ANY REPRODUCTION IN PART OR WHOLE WITHOUT THE WRITTEN PERMISSION OF MASTERPIECE ARMS INC. IS PROHIBITED.

| ITEM | PART        | DESCRIPTION               | QTY |
|------|-------------|---------------------------|-----|
| 1    | MPA930-01A  | Lower Frame Weldment      | 1   |
| 2    | MPA930-09   | MINI 9 Sear Plate         | 1   |
| 3    | MPA930-10   | MINI 9 Sear Spring        | 2   |
| 4    | MPA20-11    | 9mm Trigger Bar           | 1   |
| 5    | MPA20-12    | 9mm Trigger               | 1   |
| 6    | MPA20-13    | 9mm Trigger Pin           | 1   |
| 7    | MPA930-14   | MINI 9 Semi Wire Retainer | 1   |
| 8    | MPA20-15    | 9mm Safety Selector       | 1   |
| 9    | MPA930-16   | MINI 9/9mm Hammer         | 1   |
| 10   | MPA1-17     | 45/9mm Hammer Spring LH   | 1   |
| 11   | MPA1-18     | 45/9mm Hammer Spring RH   | 1   |
| 12   | MPA930-19   | MINI 9/9mm Hammer Pin     | 1   |
| 13   | MPA930-19-1 | MINI 9/9mm Hammer Spacer  | 1   |
| 14   | MPA930-20   | Hammer Pin Retainer       | 1   |
| 15   | MPA1-21     | 45/9mm Back Grip          | 1   |
| 16   | MPA1-22     | 45/9mm Back Grip Screw    | 1   |
| 17   | MPA20-23    | 9mm Mag. Catch (Sten)     | 1   |
| 18   | MPA1-24     | 45/9mm Mag. Catch Pin     | 1   |
| 19   | MPA1-25     | 45/9mm Mag. Catch Spring  | 1   |
| 20   | MPA1-66     | Trigger Boot              | 1   |
| 21   | MPA930-67   | MINI 9 Sear Spring Holder | 1   |

**Assembly Instructions:**

1. Install sear plate (item 2) in frame and slide towards front of gun.
2. Install sear springs (item 3) onto back posts of sear plate (item 2).
3. Insert sear spring holder (item 21) into frame as shown and slide sear plate towards rear of gun. The back of the sear spring holder must be against the back wall of the frame. Note: The wide part of the Sear Spring Holder must be at the top.
4. Install the trigger bar (item 4), oriented as shown, so that the front legs of the sear plate overlap the back of the trigger bar.
5. Insert the trigger (item 5) as shown into the corresponding slot of the frame. Doing this will push the trigger bar and sear plate back compressing the sear spring.
6. Insert the trigger pin (item 6), through the corresponding hole in the right side of the frame and then through the trigger (item 5). Do not push the pin through the hole in the left side of the frame at this point.
7. Install the safety selector (item 8). The safety selector should go all the way in until the shoulder touches the frame.
8. Install the semi wire retainer (item 7) so that the front leg goes under the frame reinforcement bar and the upside-down "V" shape at the back fits into the notch on the right side to the trigger guard. Push the semi wire retainer down until the trigger pin will go over it and into the opposing hole in the frame. The semi wire retainer should snap into the groove of the trigger pin and into the groove of the safety selector next to the inside of the frame.
9. Install the left and right hammer springs (items 10 & 11) on the hammer (item 9). This is accomplished by sliding the coiled area of the spring over the posts of the hammer then using a flat blade screwdriver, press the "hook" on the spring through the slot on the hammer. Complete this for both sides.
10. Install the hammer by inserting the tails of the hammer springs into the cavity under the sear plate. Align the hole in the hammer with the corresponding holes in the frame.
11. Insert the hammer pin (item 12) through the hole in the frame and hammer until the end of the pin is flush with the hammer. Place the hammer spacer (item 13) between the frame and hammer and then finish pushing the pin through.
12. Slide the hammer pin retainer (item 14) over the groove on the hammer pin. Using a soft object that will not scratch the side of the frame (a credit card or drivers license works well) push the retainer on to the hammer pin until it "clicks" into place.
13. At this point, the hammer should be over the magazine well. Cock the hammer. This is done by rotating the hammer up, back (toward the back of the frame) and down until it "clicks" and locks into place on the sear plate. Note: The hammer has to be in the cocked position to install the upper receiver.
14. Insert the trigger boot (item 20) onto the trigger. Proceed to install the upper receiver and bolt assembly onto the gun.

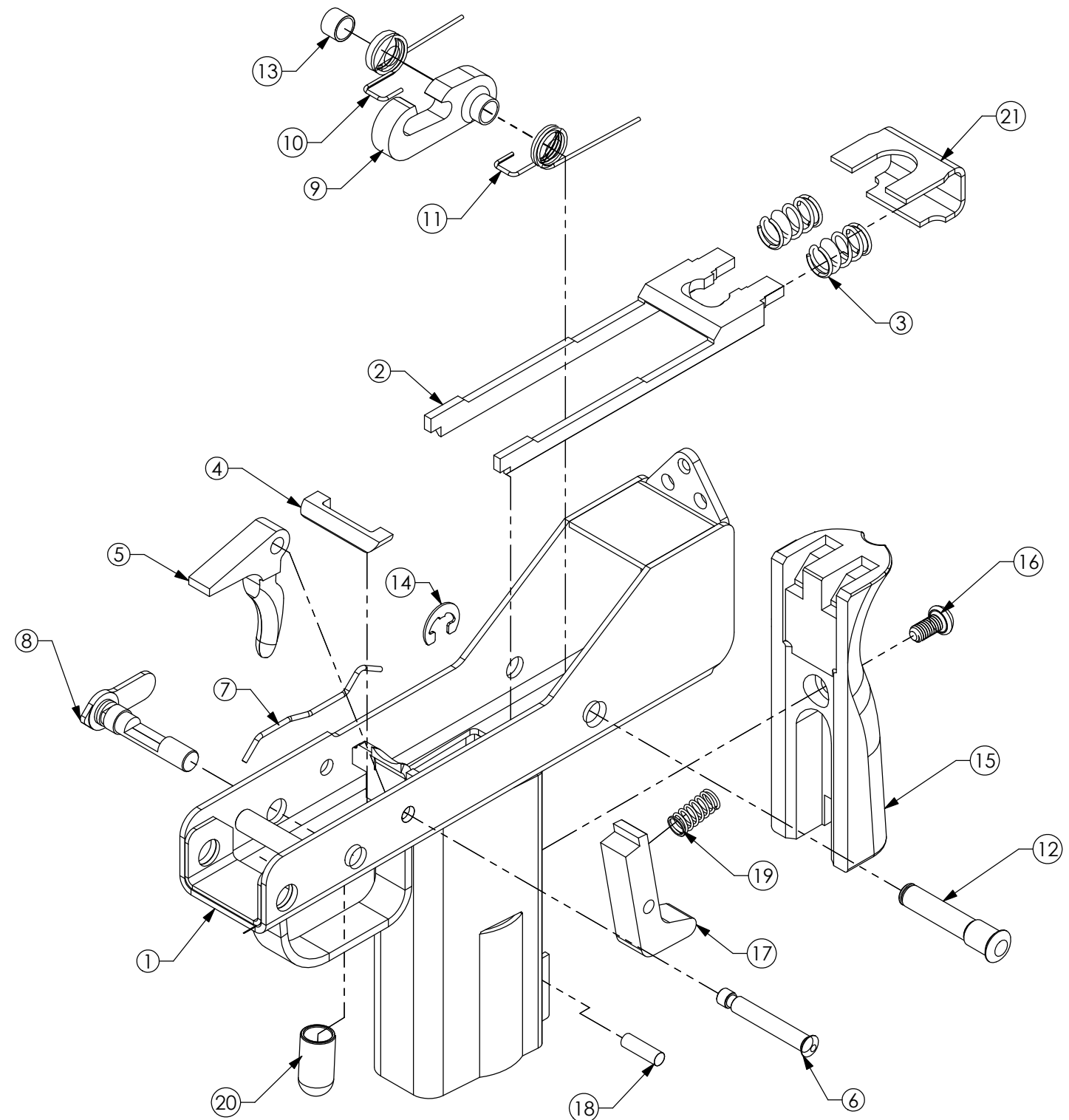

UNLESS OTHERWISE SPECIFIED Fractions ± 1/32  
 DIMENSIONS ARE IN INCHES. xx ± .015  
 TOLERANCES ARE: xxx ± .005  
 angle ± 1/2°

Drawn By: DS Date: 3/17/2008  
 Material:  
 Heat Treat:  
 Finish:

**Master Piece Arms**  
**MPA930A01B**  
**MINI 9 Lower Assembly**

Sheet1 of 1

DO NOT SCALE DRAWING

Scale 1:1.5